

FLUKE[®]

INSTRUCTION MANUAL

80T-150 TEMPERATURE PROBE

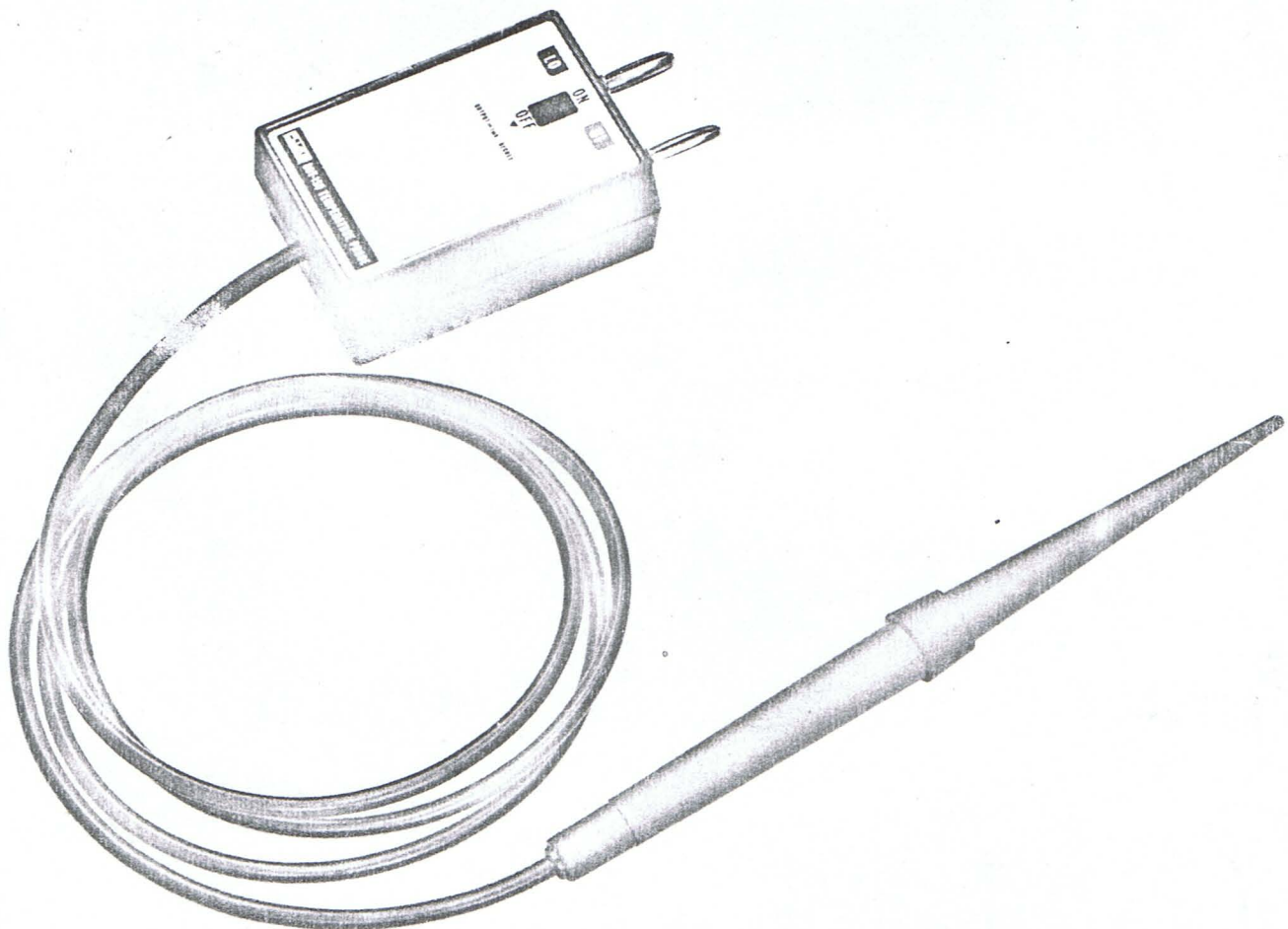

WARRANTY

The JOHN FLUKE MFG. CO., INC. warrants each instrument manufactured by them to be free from defects in material and workmanship. Their obligation under this Warranty is limited to servicing or adjusting an instrument returned to the factory for that purpose, and to making good at the factory any part or parts thereof; except tubes, fuses, choppers and batteries, which shall, within one year after making delivery to the original purchaser, be returned by the original purchaser with transportation charges prepaid, and which upon their examination shall disclose to their satisfaction to have been thus defective. If the fault has been caused by misuse or abnormal conditions of operations, repairs will be billed at a nominal cost. In this case, an estimate will be submitted before work is started, if requested.

If any fault develops, the following steps should be taken:

1. Notify the John Fluke Mfg. Co., Inc., giving full details of the difficulty, and include the Model number, type number, and serial number. On receipt of this information, service data or shipping instructions will be forwarded to you.
2. On receipt of the shipping instructions, forward the instrument prepaid, and repairs will be made at the factory. If requested, an estimate will be made before the work begins, provided the instrument is not covered by the Warranty.

"The foregoing warranty is in lieu of all other warranties, express or implied, including but not limited to, any implied warranty of merchantability, fitness or adequacy for any particular purpose or use. Fluke shall not be liable for any special, incident or consequential damages."

Section 1

Introduction & Specifications

INTRODUCTION

The Model 80T-150 Temperature Probe is a self-contained temperature-to-voltage converter. It is designed to provide a direct temperature reading when connected to any high impedance voltmeter that is capable of 1mV resolution, and at least a 300 full-scale readout capability. Two temperature ranges are provided, and either can be jumper selected; -58 to $+300^{\circ}\text{F}$ or -50 to $+150^{\circ}\text{C}$.

The unit is housed in two separate assemblies; a temperature probe and a temperature-to-voltage converter. The probe contains the temperature sensing element and is electrically connected to the temperature-to-voltage converter through a 46-inch shielded cable. Two banana plugs with standard 0.75 inch spacing are provided for connecting the 80T-150 to the voltmeter.

Operating power for the 80T-150 is derived from an internal Lithium battery. Typically, the battery will provide up to 1000 hours of continuous operation before replacement is necessary. An ON/OFF switch is provided on the temperature-to-voltage converter to allow battery conservation when the unit is not in use.

Temperature is measured by exposing the probe tip directly to the material to be measured (liquid, gas or solid).

SPECIFICATIONS

The 80T-150 will achieve rated accuracy when used with any 0.1% DVM which has an input impedance of $\geq 1\text{M}\Omega$. Specifications for the 80T-150 are given in Table 1.

Table 1. SPECIFICATIONS

ELECTRICAL		GENERAL	
Range		Weight	100 gm (3.5 oz.)
Fahrenheit	-58° to $+300^{\circ}\text{F}$	Overall Length	1.33 meters (52.5 in.)
Celsius	-50° to $+150^{\circ}\text{C}$	Power	Disposable Lithium battery, 2.9V @ 0.5 Ah. Up to 1000 hours of continuous use.
Range Selection	Internal Jumpers		
Sensitivity	1mV per $^{\circ}\text{C}$ or $^{\circ}\text{F}$		
Resolution (recommended max)	0.1°C or 0.1°F		
Accuracy	$^{\circ}\text{C}$ $^{\circ}\text{F}$		
15 to 35°C Ambient			
-50 to -25°C	± 3 ± 5.8		
-25 to $+125^{\circ}\text{C}$	± 2 ± 4		
$+125$ to $+150^{\circ}\text{C}$	± 3 ± 5.8		
0 to 50°C Ambient			
-50 to -25°C	± 4 ± 7.6		
-25 to $+125^{\circ}\text{C}$	± 3 ± 5.8		
$+125$ to $+150^{\circ}\text{C}$	± 4 ± 7.6		
Maximum Voltage (without damage), Probe Tip-to-Circuit Low	350V dc or Peak ac		
		ENVIRONMENTAL	
		Storage	Operating
		Airtitude	≥ 50000 ft. ≥ 10000 ft.
		Temperature	-40 to $+70^{\circ}\text{C}$ 0 to $+50^{\circ}\text{C}$
		Humidity	— 90% non-condensing
		Application Force (Probe tip-to-measurements surface)	20 pounds max.

Section 2

Operating Instructions

INTRODUCTION

This section of the manual should be read and understood prior to attempting to operate the 80T-150. The salient features of the probe are shown and described in Figure 1.

OPERATING NOTES

Probe Limitations

The 80T-150 probe is constructed of a highly durable plastic and is suitable for measuring the temperature of liquids, gases and solid surfaces up to 150°C. When measuring temperature, observe the following precautions to prevent damage to the probe:

- Do not expose the probe end (probe tip plus ≈ 2 inches of probe body) to temperatures in excess of +150°C. The remainder of the probe body should not be exposed to temperatures above +70°C.
- Most corrosive agents will not damage the probe body. However, the aluminum probe tip will deteriorate under long term exposure to corrosive environments.

CAUTION

Long term exposure of the probe to corrosive environments will result in pitting and deterioration of the aluminum probe tip.

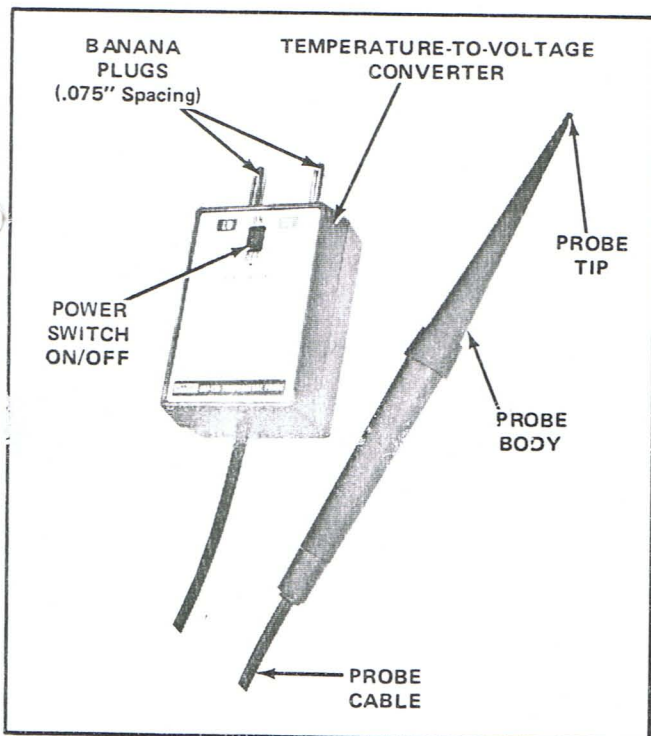

Figure 1. 80T-150 FEATURES

Temperature Scale

The 80T-150 is capable of providing temperature measurements in °C or °F. See decal opposite Power Switch for assigned temperature scale. Instructions for changing temperature scale are given in Section 4.

Error Sources

When the probe tip is applied to a solid surface it draws or sinks heat from the surface. Therefore, if the measured surface has a low mass (e.g., a transistor case), the indicated temperature may be lower than the actual temperature.

Similarly, a steady-state error or gradient exists between the measured surface and the sensing device in the probe tip. This is due to the flow of heat from the measurement surface to the probe body. The effect of the steady-state error increases as the differential between ambient and surface temperature increases.

To determine the actual surface temperature of a device, both the heat-sinking and steady-state errors must be considered. The correction curve given in Figure 2 approximates the effect of both error sources on TO-3, TO-5 and TO-18 transistor cases.

RF signals applied to the 80T-150 probe tip can also cause errors in temperature measurement. Figure 3 defines the rf signal limits that can be tolerated without degrading measurement accuracy.

OPERATION

- Connect the banana plugs on the 80T-150 to the input terminals of a high impedance voltmeter. Observe polarity.
- Select a voltage range that will provide at least 1mV resolution (1mV/degree), and a full scale readout that will encompass the expected temperature. The 1V range on a 3½ digit DVM is adequate. Ignore readings of less than 1° when a more sensitive DVM is used.
- Set the 80T-150 Power Switch to ON and energize the voltmeter.
- Firmly touch the probe tip to the surface to be measured, or expose it to a liquid or gas. The voltmeter will display the temperature in degrees. Vary probe angle and pressure when measuring solid surface temperatures; the highest stabilized reading will be the most accurate.

CAUTION

The force exerted on the probe tip should not exceed 20 pounds.

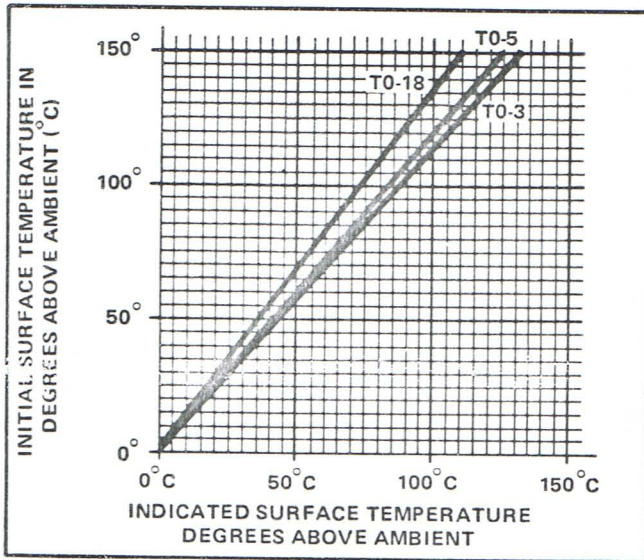

Figure 2. INITIAL CASE TEMPERATURE ABOVE AMBIENT VS. METER READING ABOVE AMBIENT

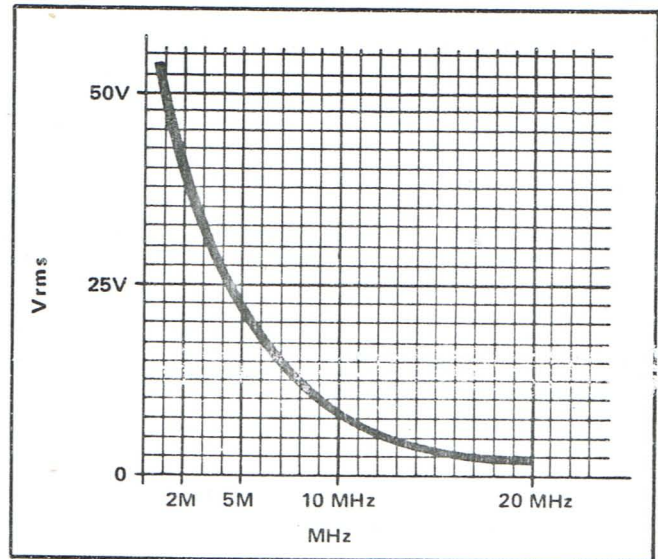

Figure 3. MAXIMUM RF SIGNAL LIMITS (Vrms) AT PROBE TIP

Section 3

Theory of Operation

The Model 80T-150 utilizes the negative temperature coefficient of a semiconductor (P-N) junction to measure temperature. The PN junction is thermally integrated into the probe tip and comprises one leg of a bridge circuit as shown in simplified circuit diagram section of Figure 6. A 2.9V Lithium battery is used to power both the bridge circuit and operational amplifier U2. Since the bridge must be balanced to provide 0°C and 0°F indications, separate range or temperature scale resistors R_A and R_B are included in the bridge circuit. When R_B is shorted, the °C scale is selected and the bridge is calibrated by R2 to null at 0°C. Conversely, when R_B is open, the °F scale is selected and the bridge is calibrated by R2 to null at 0°F. Deviations above and below 0° provide a bridge output of approximately 2.45mV/°C.

Operational amplifier U2 is used to measure the bridge output and scale it to a 1mV/degree signal. Since the °C and the °F scale are sloped differently, the scale for U2 must be matched with the scale selected for the bridge circuit. Shorting resistor R_D selects the °C scale. Conversely, when R_D is open the °F scale is selected. Resistor R4 calibrates both scales.

The output voltage used to drive the external voltmeter is taken from the output of U2 (P2) and the reference side of the bridge (P1). Since U2 is operating as an inverting amplifier, its output is used as the low input to the voltmeter. This enables the voltmeter to display an increase in temperature as an increase in voltage.

Section 4

Maintenance

INTRODUCTION

This section of the manual contains maintenance information for the Model 80T-150. This includes general maintenance, a performance test and calibration. A calibration cycle of 1 year is recommended to maintain the unit within the specifications given in Section 1. The equipment required for both the performance test and calibration is listed in Table 2. Warranty information is given at the front of this manual.

GENERAL MAINTENANCE

Access Information

The battery, the temperature scale jumpers and the calibration pots are located on the interior of the temperature-to-voltage converter assembly. Access to these locations is accomplished by removing the three screws from the bottom side of the assembly and removing the plastic box.

Table 2. TEST EQUIPMENT REQUIREMENTS

Instrument Type	Minimum Use Specifications	Recommended Model
Mercury Thermometer	0.1°C Resolution	Princo Model SAMA-CP45
Dewar Flask and Cap	1-pint capacity (for ice bath)	Thermos Bottle
Metal or Glass Container	1-pint capacity	Suitable for boiling water
Digital Volt Meter	100 mV range with 10 μ V Resolution 1000 mV range with 100 μ V Resolution	Fluke Model 8600A

Battery Replacement

CAUTION

When replacing battery, exercise professional soldering practices. Careless soldering can damage the pcb and void the warranty.

The 2.9v lithium battery (John Fluke pn 424523) has a useful life of \approx 1000 hours. Contact your nearest Fluke Technical Service Center for replacement and/or installation. Battery installation is accomplished by unsoldering the old battery and soldering a new one in place. Polarity markings on pcb indicate proper battery alignment.

Temperature Scale Jumpers, °C or °F

The jumper locations for selecting either the °C or °F temperature scale are shown in Figure 4. The absence of jumpers at both points indicates selection of the °F scale. The presence of solder bridges at both points indicates selection of the °C scale. Under no circumstances should one point be open while the other is bridged.

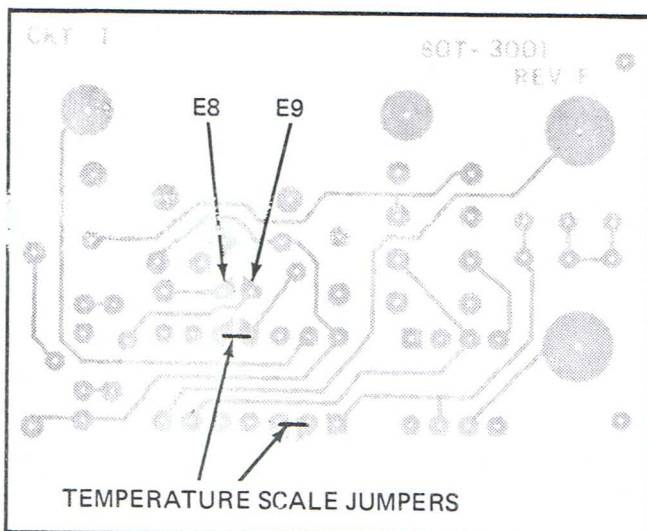

Figure 4. TEMPERATURE SCALE JUMPERS

PERFORMANCE TEST

Complete the calibration procedure without opening the temperature-to-voltage converter assembly and without making any calibration adjustments. Observe the readings given in [brackets]. Other readings are for calibration only.

CALIBRATION

NOTE

Values given in brackets apply to the Performance Test.

- Access the interior of the temperature-to-voltage converter.
- Determine the selected temperature scale (°C or °F). See marking on bottom cover decal.
- Connect the 80T-150 to a DVM and select the 100mV dc range (10 μ V resolution).
- Turn the 80T-150 power switch to ON and immerse the probe tip \approx 2 inches into a thermometer monitored 0°C bath. Allow the DVM reading to stabilize (\approx 30 seconds).
- Adjust R2 (See Figure 5.) to obtain the appropriate DVM reading:

°C	0.00 \pm 0.05mV dc	[0 \pm 2mV dc]
°F	32.0 \pm 0.1mV dc	[32.0 \pm 4mV dc]

 If necessary, additional cw range can be added to R2 by adding a solder bridge across E8 and E9 as shown in Figure 4.
- Immerse the probe tip approximately 2 inches into a 70 to 100°C bath and allow the DVM reading to stabilize. Change DVM range, if necessary for °F calibration.
- Adjust R4 to obtain a DVM reading which agrees with the bath temperature (BT) as monitored by a mercury thermometer.

°C	BT \pm 0.05mVdc	[BT \pm 2mVdc]
°F	BT \pm 0.1 mVdc	[BT \pm 4mVdc]

NOTE

If the unit is calibrated on the °F scale some interaction will occur between adjustments R2 and R4. Repeat steps d, e, f and g until readings are obtainable without adjustment.

PROBE REPLACEMENT

Replacement probes are accompanied by three resistors. Solder the new probe and cable assembly to the pcb and attempt to calibrate the unit. If R2 reaches a limit (step e. of calibration procedure) determine value of R3 on the pcb. Replace R3 with a lower value resistor (32.4K or 64.9K) if zero is high, or higher value resistor (64.9K or 127K) if zero is low. Complete remainder of calibration procedure.

LIST OF REPLACEABLE PARTS

Component location drawings and a list of replaceable parts are shown in Figure 5. When ordering parts, provide description, Fluke pn and quantity required.

MODEL 80T-150 FINAL ASSEMBLY			TEMPERATURE CONVERTER PCB ASSEMBLY				
REF. DESIG.	DESCRIPTION	FLUKE P/N	TOTAL QTY.	REF. DESIG.	DESCRIPTION	FLUKE P/N	TOTAL QTY.
A1	Sensing Probe and Cable Assembly (includes selected resistor R3)	421023 451023	1	C1, C3, C4, C5	Cap, disc, 0.01 uF ±20%, 100V dc	149153	4
A2	Temperature-to-Voltage Converter PCB Assembly	432591	1	C2	Cap, disc, 2.2 uF ±20%, 20V dc	161927	1
BT1	Battery, Lithium, 2.9V @ 0.5 Ah	424523	1	J1, J2	Socket, 1-pin	343285	2
P1, P2	Plugs, banana	352716	2	R1	Res, metal film, 1.62k ±1%, 1/8W	283697	1
R3	Resistor, selected (supplied with A1 Assy) (32.4K, 64.9K or 127K)	—	1	R2	Res, variable, 2k, 1/2 W	226076	1
1	Button, switch, green	432575	1	R3	See Final Assembly	225417	1
2	Housing, bottom	434621	1	R4	Res, variable, 50k, 1/2W	393629	1
3	Housing top (not shown)	432567	1	S1	Switch, slide	424499	1
				U1	Resistor Network	418913	1
				U2	IC, linear op amp	429852	1
				VR1	Diode, zener, 1.22V dc		1

Figure 5. LIST OF REPLACEABLE PARTS

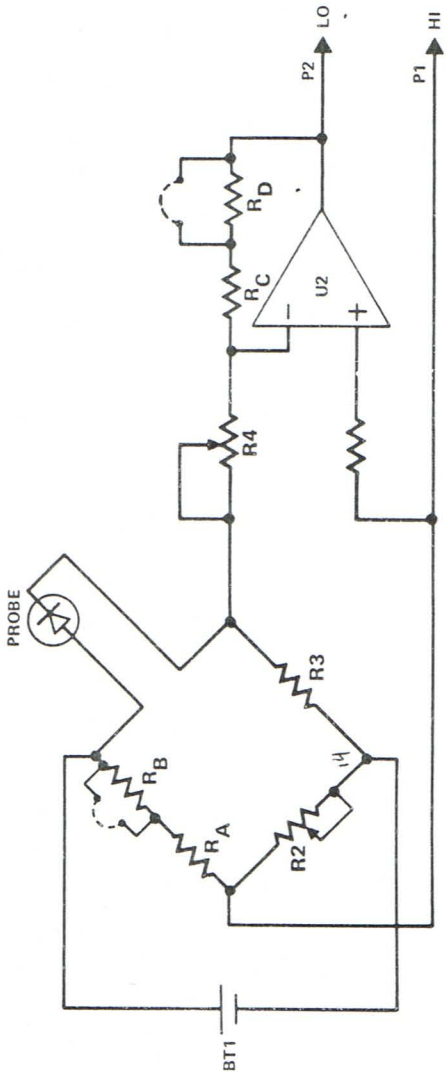

SIMPLIFIED
CIRCUIT
DIAGRAM

NOTES:



1 Part of resistor network U1

2. Unless otherwise noted, all capacitance is in uF, and all resistance is in ohms

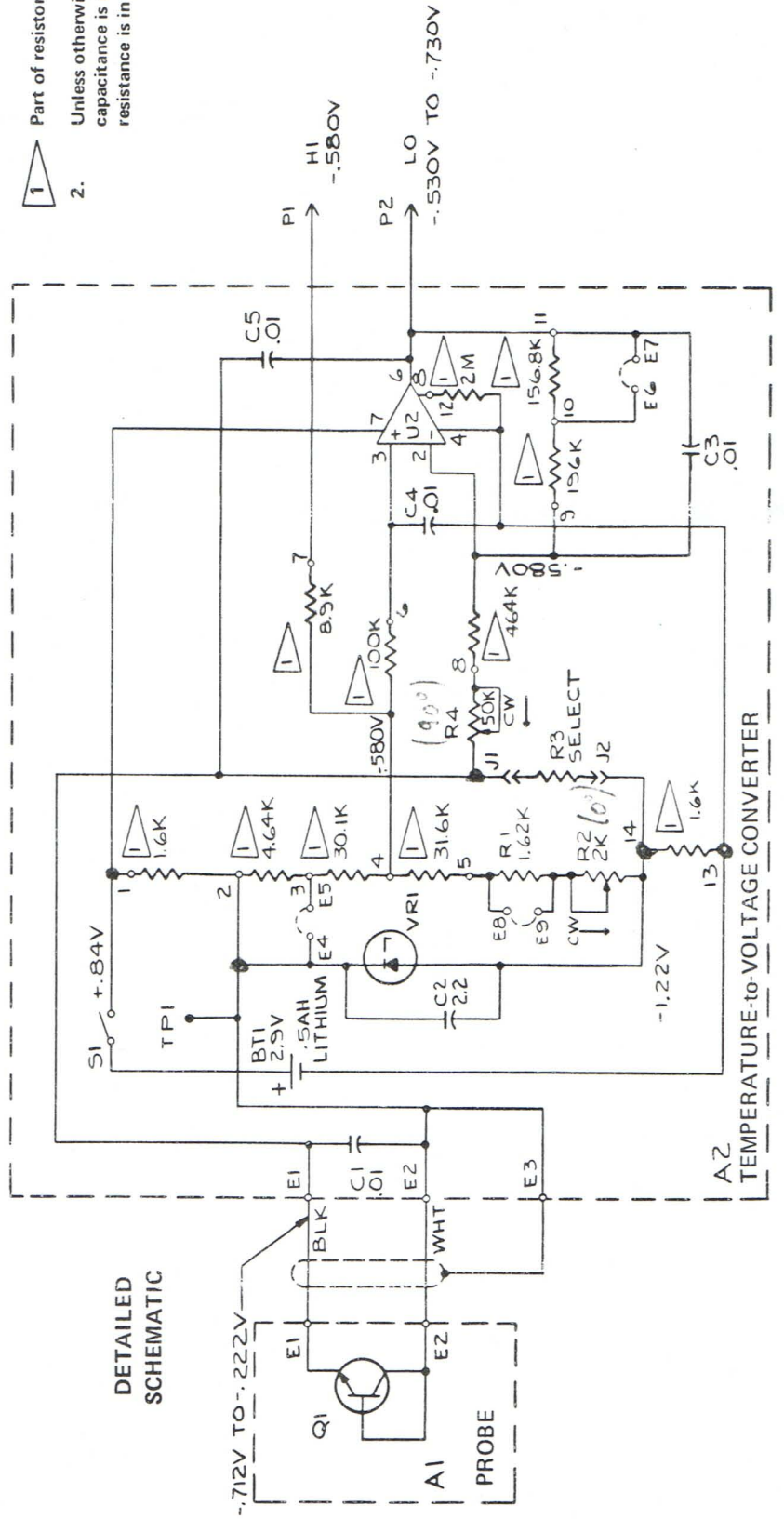

DETAILED
SCHEMATIC

Figure 6. 80T-150 TEMPERATURE PROBE ASSEMBLY (80T-1201)

80T-150-7001K PROBE KIT INSTALLATION AND CALIBRATION INSTRUCTIONS

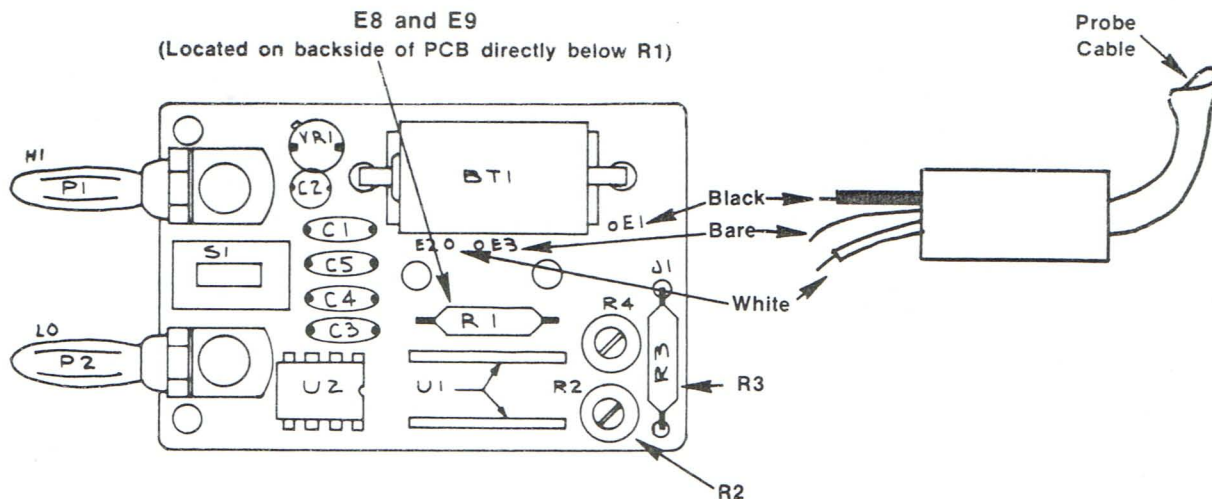

Figure 1.

INSTALLATION

1. REMOVE THE TOP-COVER FROM THE 80T-150 TEMPERATURE-TO-VOLTAGE CONVERTER.
2. NOTE THE LOCATION OF THE WHITE, BLACK, AND BARE CABLE LEADS (SEE FIGURE 1).

CAUTION

WHEN REPLACING THE PROBE CABLE, EXERCISE PROFESSIONAL SOLDERING PRACTICES. CARELESS SOLDERING CAN DAMAGE THE PCB AND VOID THE WARRANTY.

3. CLIP THE TIE-WRAP (D) AND UNSOLDER THE THREE CABLE LEADS FROM THE PCB.
4. REMOVE ALL REMAINING SOLDER FROM THE THREE, PLATED-THRU HOLES.
5. FIRMLY ANCHOR THE NEW CABLE ASSEMBLY TO THE PCB USING THE TIE-WRAP PROVIDED IN THE PROBE KIT.
6. INSERT THE BLACK, WHITE, AND BARE WIRES IN THEIR RESPECTIVE HOLES AND SOLDER THEM TO THE PCB.
7. CLIP-OFF EXCESS LEAD LENGTH ON BOTTOM SIDE OF PCB.

CALIBRATION

1. PREPARE A LAG BATH OF BETWEEN 0 AND 25°C, AND MONITOR IT USING AN ACCURATE MERCURY THERMOMETER.
2. MEASURE THE TEMPERATURE OF THE LAG BATH USING THE 80T-150.
3. ADJUST R2 (SEE FIGURE 1) UNTIL THE PROBE READING AGREES WITH THE MONITORED LAG-BATH TEMPERATURE. IF R2 REACHES A LIMIT, NOTE WHETHER THE READING IS ABOVE OR BELOW THE LAG-BATH TEMPERATURE, AND BY HOW MUCH. ALSO, CHECK TO SEE IF JUMPER POINTS E8 AND E9 ON THE PCB ARE OPEN OR SHORTED. THEN REFER TO THE TABLE BELOW AND EXERCISE THE CORRECTION THAT AGREES WITH YOUR OBSERVATIONS.

OBSERVATIONS		CORRECTION
FINAL READING	E8 AND E9	
LOW BY $\leq 5^{\circ}\text{C}$ (9°F)	OPEN	SHORT E8 AND E9
HIGH BY $\leq 5^{\circ}\text{C}$	SHORTED	OPEN E8 AND E9
LOW BY $> 5^{\circ}\text{C}$	DISREGARD	*REPLACE R3 WITH LARGER VALUE
HIGH BY $> 5^{\circ}\text{C}$	DISREGARD	*REPLACE R3 WITH SMALLER VALUE

*USE RESISTORS SUPPLIED WITH PROBE KIT.

4. REPEAT STEPS 2 AND 3 OF THIS PROCEDURE UNTIL R2 CAN BE PROPERLY ADJUSTED.
5. COMPLETE THE ENTIRE CALIBRATION PROCEDURE GIVEN IN THE 80T-150 INSTRUCTION MANUAL.